



HASO

SWIR LIFT 160

Wavefront sensor
The Prodigy

Ultra-high resolution
SWIR range
Alignment-free



 compatible



HASO SWIR LIFT 160 +

A great choice for the most demanding SWIR optical metrology applications, the HASO SWIR LIFT 160 wavefront sensor provides the highest resolution in SWIR.

This generation features the new SpotTracker™ technology. It provides absolute wavefront and tilt information, eliminating alignment requirements for faster and easier implementation.



Compatible with the **Optical Engineer Companion** modular system: easily combine the accessories you need.

APPLICATIONS

Successfully used in the most demanding applications in optical metrology, microscopy, and laser diagnostics, the HASO SWIR LIFT 160 performs multiple functions :

- + Optical manufacturing metrology
- + Complex optics characterization
- + Middle frequencies mirror surface characterization
- + Optical quality control, metrology (LIDAR, free space communication, Automotive, Space and defense)
- + Predict the performance of optical systems in terms of focusing capability or imaging quality
- + Drive a wavefront corrector to correct for system aberrations
- + Quantify the effects of temperature and gravity on system performance

FEATURES

- + Direct wavefront acquisition of highly converging and diverging beams with an accuracy of $\lambda/100$ RMS, including astigmatism and high-order aberrations, and many other parameters, making it the perfect instrument for any complex optics alignment
- + Beam collimation with sensitivity > 1 km radius of curvature
- + Control and adjustment of axial laser beam deviation $> 3 \mu\text{rad}$ RMS
- + Complex optics characterization in single or double path configuration in combination with R-FLEX2 metrology systems or R-FLEX LA metrology platforms
- + 3D MTF measurements



SPECIFICATIONS*

OPERATING SPECS

Aperture dimension	9.3 x 7.4 mm ²
Phase sampling	160 x 128
Maximum acquisition frequency	150 Hz (USB 3.0) or 49 Hz (GigE)
Calibrated wavelength range	1.05 - 1.70 μm
Minimum power	1 pW
External trigger	TTL signal
Operating system	Windows 10

OPTICAL SPECS

Repeatability	λ/200 RMS
Absolute wavefront measurement accuracy	λ/100 RMS
Spatial sampling	58 μm
Tilt dynamic range	> ± 3°
Focus dynamic range	± 0.040 m to ± ∞

MISC

Dimension	75 x 78 x 63 mm ³ (USB 3.0)
Weight for USB version	250 g
Working temperature	15 - 30 °C
Interface	USB 3.0 or GigE
Power consumption	< 5 W

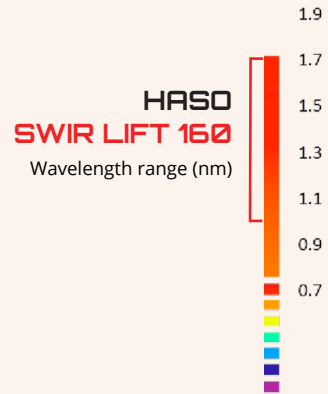

HASO SWIR LIFT 160

Dynamic range at λ = 1550 nm

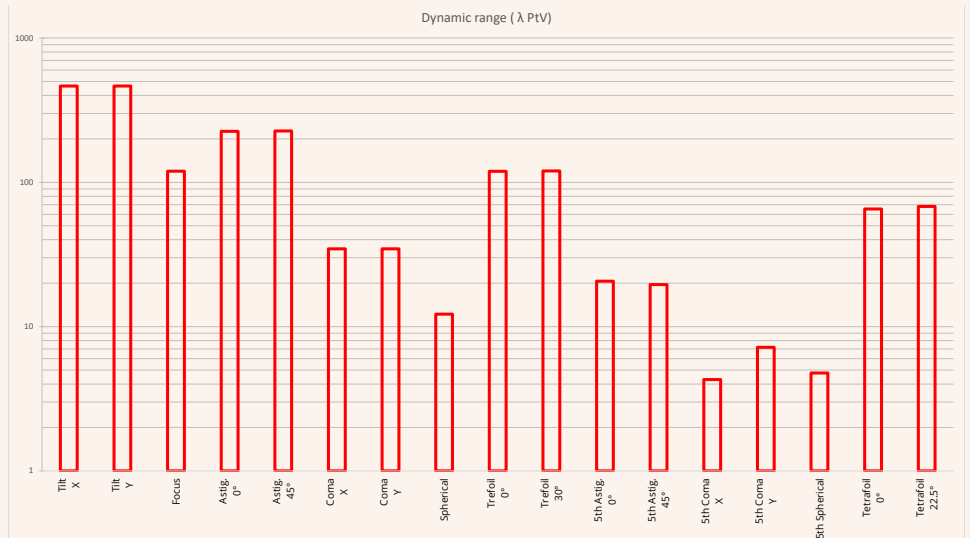

*Subject to changes without further notice

DIMENSIONS** (mm)

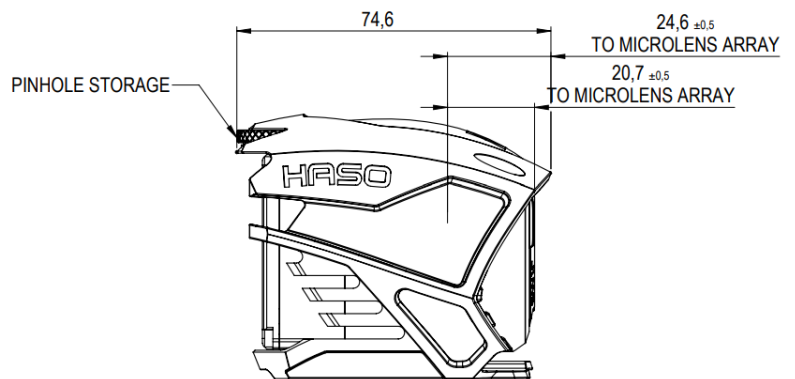
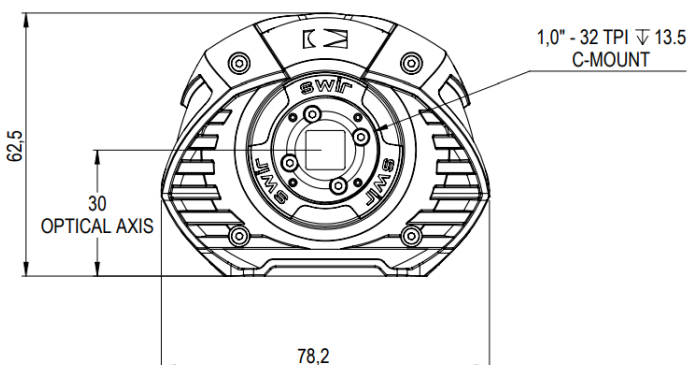

**USB 3.0 model

SOFTWARE

WAVEVIEW™ Metrology Software

WAVEVIEW™ is the most advanced wavefront measurement and analysis software.

It offers more than 150 features and tools optimized for a wide range of highly demanding applications.

Options :

- + Extensions for PSF, MTF and Strehl ratio
- + Optional SDK in C/C++, LabVIEW and Python

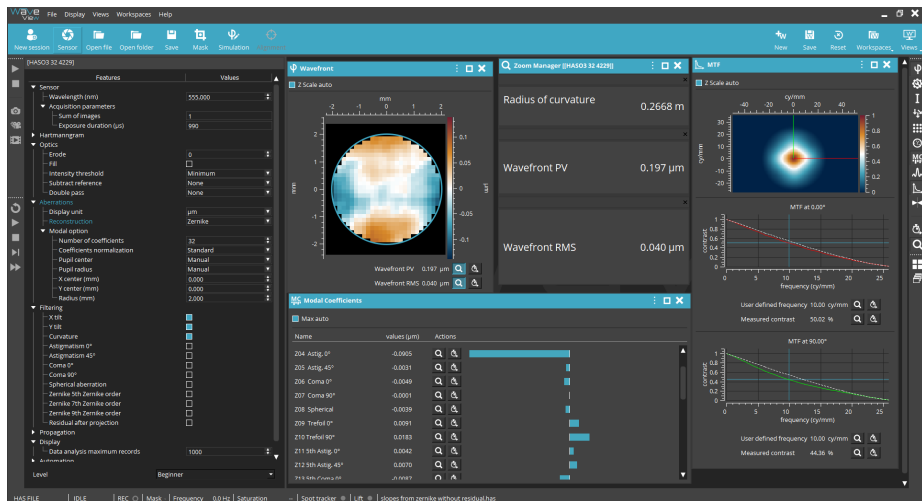

WAVETUNE™ Adaptive Optics Software

WAVETUNE™ is a unique software that seamlessly combines wavefront measurement and correction features with extensive instrument diagnostics.

It is perfectly adapted to our HASO wavefront sensors, ILAO STAR, MIRAO and mu-DM deformable mirrors, as well as to a wide range of active components.

Options :

- + Optional SDK in C/C++, LabVIEW and Python

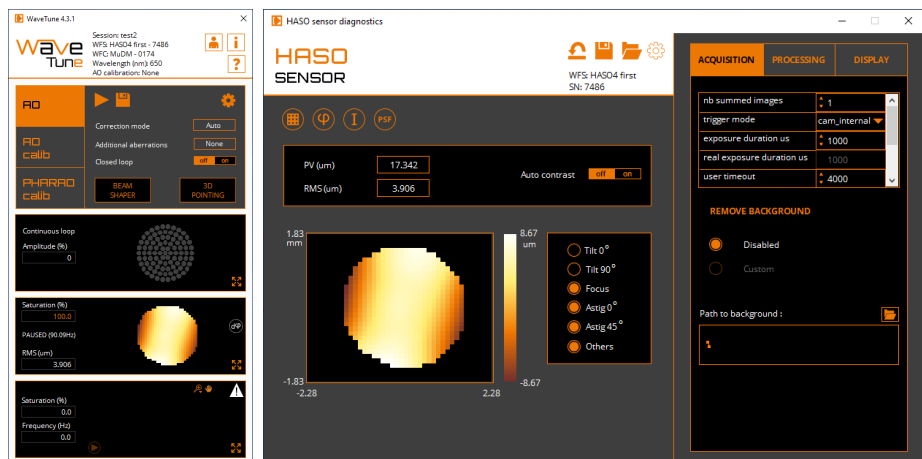

CONTACT US

Imagine Optic Headquarters
18, rue Charles de Gaulle
91400 ORSAY · France
Phone +33 (0)1 64 86 15 60
sales@imagine-optic.com
www.imagine-optic.com

