



CAM SQUARED

M2 meter
The smart one

Compact
Alignment-Free
Ultra short measurement cycle +



CAM SQUARED +

A great choice for almost any lab or industrial application, the CAM SQUARED is Imagine Optic's innovative answer to the need for laser quality testing and M^2 measurement.

Finally an M^2 meter as easy and quick to set up as a beam profiler.

APPLICATIONS

Laser beam quality testing is of utmost importance in many laser-based applications where beam waist and beam divergence matter:

- + Manufacturing, machining, welding for fluence
- + Imaging, for resolution
- + Fiber optics, for coupling
- + Free space optical communications and laser radar systems (LIDAR) for better propagation through turbulent atmosphere.

CAM SQUARED performs multiple measurements : M^2 , divergence, focus diameter, waist position, Rayleigh length, thermal effects.

FEATURES

- + **ISO 11146 standard compliant.** The measurement of intensity combined with phase allows to generate 10 to ∞ of intensity frames from which is calculated the M^2 factor, such as described in the ISO 11146 standard.
- + **Self aligned.** CAM SQUARED requires no alignment, making setup quick and easy.
- + **Short measurement cycle.** CAM SQUARED requires no translation, making measurement cycle very short and the solution perfectly adapted to pulsed lasers and dynamic applications.
- + **Optics free.** As no mirrors nor lenses are necessary, there are no optics introducing aberrations which impair the beam quality. There are also no coatings limiting the range of use of the sensor.
- + **SM1 thread** on the front of the sensor for easy mounting of optical densities in order to adapt to the power of the laser to be tested.



SPECIFICATIONS

OPERATING SPECS

Aperture dimensions	6.9 x 5.1 mm ² (L) 4.5 x 3.7 mm ² (M)
Recommended beam diameter	min.: 0.8 mm @ 1/e ³ (0.7 mm @ 1/e ²) max. (L): 5 mm @ 1/e ³ (4.5 mm @ 1/e ²) max. (M): 3.6 mm @ 1/e ³
Maximum acquisition frequency	55 Hz (L) 125 Hz (M)
Wavelength range	350 - 1100 nm
Minimum power	0.15 nW
External trigger	TTL signal
Operating system	Windows 10 & 11
Measurement cycle time	~ ms typically, depending on settings
Travel range	not limited by translation stage
Typical M ² accuracy	5%
Pulsed sources	full compatibility
Damage thresholds	100 mW / cm ² in CW mode 100 uJ / cm ² in Pulsed mode

MISC

Dimensions (Height x Width x Length)	50 x 50 x 55 mm ³
Weight for USB version	200 g
Mounting configuration	horizontal or vertical
Working temperature	15 - 30 °C
Interface	Ethernet or USB 3.0
Power consumption	3.1 W

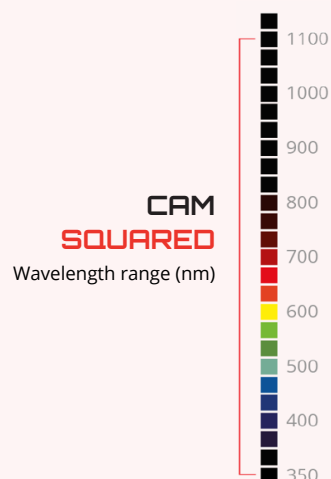

DIMENSIONS (mm)

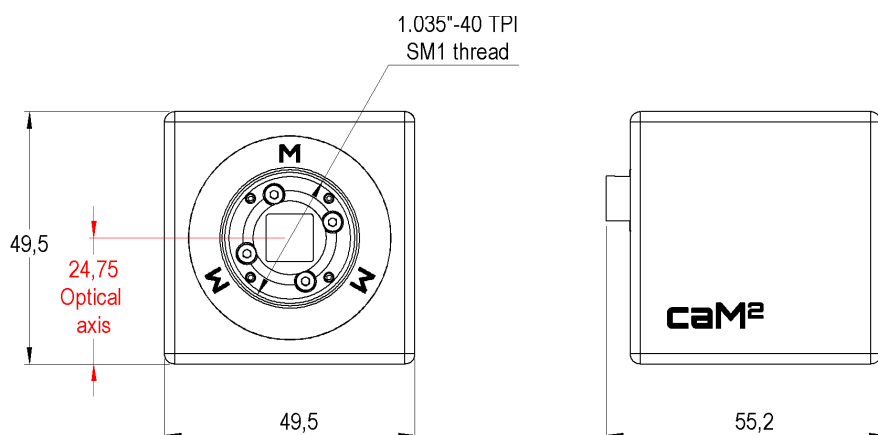

SOFTWARE

Application M2 based on WAVEVIEW™ Metrology Software

- + Optimized display of laser quality metrics
- + Optional phase measurement extension for wavefront diagnostic and analysis (alignment, collimation, optical aberrations analysis and more than 150 features)
- + Optional SDK in C/C++, LabVIEW and Python

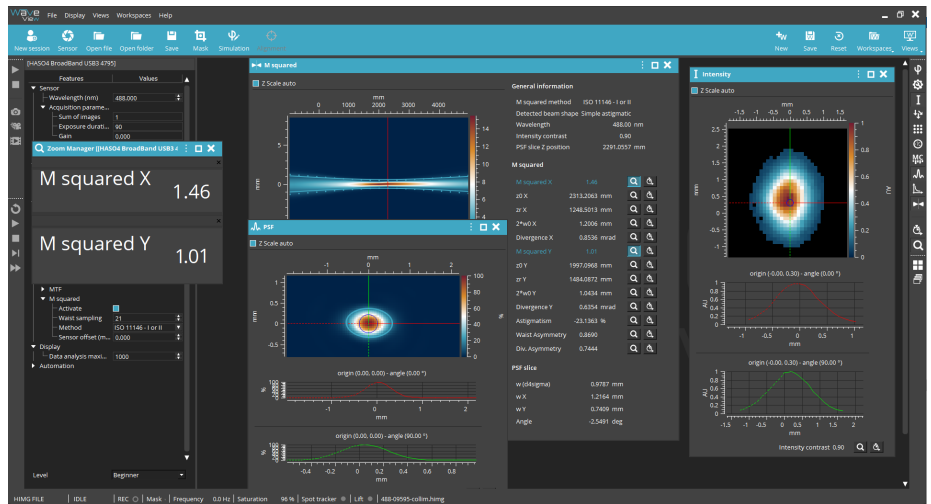

ACCESSORIES

- + Several mounting options are available, including adapters for the most common mechanical stages and magnetically coupled top and bottom plates, allowing to mount, remove, and replace CAM SQUARED with a high repeatability.

APPLICATION NOTES

- + M2 measurement with CAM SQUARED



CONTACT US

Imagine Optic Headquarters
18, rue Charles de Gaulle
91400 ORSAY · France
Phone +33 (0)1 64 86 15 60
sales@imagine-optic.com
www.imagine-optic.com

